



July 2013

CAVAN-TYRONE & MEATH-CAVAN 400 KV TRANSMISSION CIRCUITS

TECHNOLOGY AND COSTS UPDATE

Addendum to the 2009
Report and
Supplementary Note

**PARSONS
BRINCKERHOFF**



April 2013

CAVAN-TYRONE & MEATH-CAVAN 400 KV TRANSMISSION CIRCUITS

COMPARISON OF HIGH VOLTAGE
TRANSMISSION OPTIONS:

ALTERNATING CURRENT
OVERHEAD & UNDERGROUND, &
DIRECT CURRENT UNDERGROUND

TECHNOLOGY AND COSTS UPDATE

SINCE PUBLICATION OF THE 2009
REPORT

*Prepared for Northern Ireland Electricity and
for EirGrid*

3511435A

FINAL

**PARSONS
BRINCKERHOFF**

CAVAN-TYRONE & MEATH- CAVAN 400 kV TRANSMISSION CIRCUITS

**Comparison of High Voltage Transmission
Options:**

**Alternating Current Overhead & Underground,
& Direct Current Underground**

Technology and Costs Update

Since Publication of the 2009 Report

Delivered to
Northern Ireland Electricity
120 Malone Road,
Belfast,
BT9 5HT
United Kingdom

Prepared by
Parsons Brinckerhoff
Westbrook Mills
Godalming,
Surrey, GU7 2AZ
United Kingdom

Report Title	:	CAVAN-TYRONE & MEATH-CAVAN 400 kV TRANSMISSION CIRCUITS Comparison of High Voltage Transmission Options: Alternating Current Overhead & Underground, & Direct Current Underground
		TECHNOLOGY & COSTS UPDATE Since Publication of the 2009 Report
Job No	:	3511435A

DOCUMENT HISTORY AND STATUS

Document control			
Prepared by	Mark L Winfield Allan Burns Norman MacLeod Slava Rapoport Martin Safranek	Checked by <i>(technical)</i>	Andrew Pearce (Technical Director)
Approved by	Mo Deif 	Checked by <i>(quality assurance)</i>	Andrew Pearce (Technical Director)
Revision details			
Version	Date	Pages affected	Comments
1	April 2013		Final

CONTENTS

	Page
Executive Summary	3
1 Introduction	5
1.1 Background	5
1.2 The Need for this Update	5
1.3 Scope of Work	6
1.4 Which Costs?	6
1.5 Information Sources	7
1.6 Content of this Addendum	7
1.7 Format of the Cost Estimate Tables	7
2 Recent Transmission Technology Changes	8
2.1 General	8
2.2 Overhead Lines – No Significant Technical Changes	8
2.3 Underground Cables – Improved Backfill, and Higher DC Voltages	8
2.4 HVDC – VSC Designs	9
2.4.1 Technical Improvements	9
2.4.2 Future Availability of HVDC Circuit Breakers	10
2.4.3 Implications of a Single Tyrone – Meath HVDC Circuit	11
2.4.4 Relevance of East-West Interconnector Infrastructure	12
2.4.5 Summary of Position on HVDC Technology	13
3 The Chapter 8 Cost Tables and Paragraphs	14
3.1 General	14
3.2 Costing Assumptions and Approximations	14
3.3 Section 8.3 HVAC OHL Costs: Table 8-1 – Table 8-4	16
3.3.1 Assumptions	17
3.3.2 The Tables	17
3.4 Section 8.4 HVAC UGC Costs: Table 8-5 – Table 8-22	21
3.4.1 Assumptions	22
3.4.2 The Tables	22
3.4.3 Assumptions	33
3.4.4 Strategic Spares Holding	34
3.4.5 The Tables	34
3.5 Switchgear and Transformer Costs	36
4 The Chapter 9 Costs Conclusions	38
4.1 Paragraphs 542 to 548 in Section 9.3 of the 2009 Report	38
4.2 Paragraphs 551 to 553 in Section 9.4 of the 2009 Report	39
5 Bibliography	41
6 Glossary and Acronyms	43
Appendix A - International Expert Commission (RoI IEC) Review - Responses	45
Appendix B – Summary Cost by Company	47

List of Figures

	Page
Figure 1 - Costed and Non-Costed Equipment – the Overhead Line Option	16
Figure 2 - Costed and Non-Costed Equipment – the Underground Cable Option	21
Figure 3 - Costed and Non-Costed Equipment – the HVDC Underground Option	33

List of Tables

	Page
Table 3-2, p28 – Assumptions for losses calculations	17
Table 8-1, p95 – Unit Costs of HVAC OHL	18
Table 8-2, p96 – OHL Lengths and Cost Estimates	19
Table 8-3, p96 – OHL Maintenance Costs	19
Table 8-4, p98 – OHL Discounted Cash Flow – Lifetime Costs Example	20
Table 8-5, p99 – AC Cable Parameters: Assumptions	23
Table 8-6, p101 – Civil Engineering – Preliminary Works Costs	23
Table 8-7, p101 – Civil Engineering – Preliminary Works Costs by Route Section	24
Table 8-8, p102 – Civil Engineering – Estimated Costs per km	24
Table 8-9, p103 – Trenchless Crossings – Unit Cost	25
Table 8-10, p103 – Special Civil Works Lump Sum Costs	25
Table 8-11, p104 – Special Civil Works Lump-Sum Costs by Route Section	26
Table 8-12, p105 – Summary of Civil Works Lump-Sum Costs, by Route Section	26
Table 8-13, p107 – Intermediate Reactive Compensator Costs	27
Table 8-14, p108 – Static Var Compensator Costs	27
Table 8-15, p108 – Summary of Compensation Costs	27
Table 8-16, p109 – Underground Cable Unit Costs	27
Table 8-17, p110 – Terrain Types, Corridor Lengths, Lengths Allowances	28
Table 8-18, p111 – Terrain Pattern Lengths by Corridor Section	29
Table 8-19, p112 – Terrain Pattern, Drum Length and Unit Costs	29
Table 8-20, p112 – UGC Installed Costs, by Corridor Section	30
Table 8-21, p101 – Cash Flow Discount Rate and Maintenance	30
Table 8-22, p115 – UGC Discounted Cash Flow – Lifetime Costs	31
Table 8-23, p116 – Comparative costs of HVDC solutions	34
Table 8-23a – HVDC with UGC Discounted Cash Flow – Lifetime Costs	35
Table 8-23b – Switchgear Cost Estimates	37
Table 9-1, p136 – Summary of Cost Estimates for the Whole N-S Link	38

EXECUTIVE SUMMARY

1. Significant changes are currently planned for the structure of the island of Ireland electricity supply network. One major component of the plan, an interconnector often referred to as "the North-South Link (N-S Link), comprises two single transmission circuits linking Tyrone to Cavan and Cavan to Meath.
2. Overhead line (OHL) has been the standard transmission technology around the world for many years, however feasible alternatives to OHL do exist for some transmission applications so, in 2008, EirGrid and Northern Ireland Electricity (NIE) jointly commissioned Parsons Brinckerhoff to consider the alternatives to 400 kV alternating current (AC) OHL for the N-S Link.
3. The results of this study, which included on-site assessments as well as a desk-top review by technical specialists, was reported in February 2009 – see Bibliography reference (1), and is referred to in this document as the '2009 Report'. However, in order to pursue their planning applications, NIE and EirGrid now require an update of the technical options and cost estimates provided there. They have thus requested Parsons Brinckerhoff to provide this cost update in the light of any recent technical developments. This present document reports the results of that task.
4. Comparative cost estimates have been provided for 400 kV AC overhead line and underground cable (UGC) options, and for a high voltage direct current (HVDC) voltage sourced converter (VSC) underground cable option. In all cases the estimates assume the full Tyrone – Cavan – Meath route would be built.
5. Alternative configurations of the HVDC options have been considered – in particular, the use of 1500 MW capacity converters and HVDC circuit breakers, and exploitation of the existing HVDC East-West interconnector. However, some of these technologies are still developing into commercial reality, and a separate 3-terminal link using 720 MW terminals, as costed and compared in this document, appears to be the best techno-economic HVDC option at present.
6. These cost estimates offer a comparison between alternative technologies for the N-S Link, but do not attempt to include all the costs for the final N-S Link project. In particular, other work at the three connecting substations, and work on other parts of the network that might be required at the same time, is not included. We provide single line diagrams that indicate, for each alternative, what equipment has been costed.
7. Whole-of-life cost estimates are presented – that is, the cost of planning and constructing the equipment, and the cost of running it throughout its life. The discounted cash flow technique is used to compare these lifetime costs; a discount rate of 8.1% is applied – see Section 3.2 of this document for further details.
8. Our estimates for the full Tyrone – Cavan – Meath route are summarised in the following table. Please note that the currency values here have been rounded to the nearest €5M.

Total: Turleenan - Kingscourt - Woodland €M			
	AC OHL (base case)	AC UGC	HVDC-VSC UGC
Construction + IDC	125	890	990
Transformers and switchgear	40	45	15
Construction Total	165	935	1005
Lifetime running	55	90	110
40 year replacement	5	45	55
Whole of life Total	225	1070	1170
Lifetime difference above OHL (€M)	0	845	945
Construction difference ratio (times)	1	5.7	6.1
Lifetime difference ratio (times)	1	4.8	5.2

Source: Tables in this Addendum

9. The above costs are presented separately for each Company – NIE, and EirGrid – in Appendix B.
10. In summary, the most cost effective solution for the proposed N-S Link would be an AC overhead line, estimated to cost around €165M to construct and around a further 35% of this to run over its lifetime.
11. An AC underground cable is estimated to cost over 5.7 times as much as AC overhead line to construct, and would also cost significantly more than overhead line to run, over its lifetime.
12. Similarly, HVDC UGC links would be expected to cost 6 times as much as AC overhead line to construct, and would then cost twice as much as overhead line to run, over its lifetime.

1 INTRODUCTION

1.1 Background

13. Significant changes are currently planned for the structure of the island of Ireland electricity supply network. One major component of the plan, often referred to as “the North-South Link (N-S Link), comprises two single transmission circuits linking Tyrone to Cavan and Cavan to Meath. Together, these two circuits would significantly strengthen the existing transmission network, to the benefit of both Northern Ireland (NI) and the Republic of Ireland (RoI).
14. The N-S Link plans represent a close collaboration between Northern Ireland Electricity Ltd (NIE) and EirGrid plc (EirGrid), and the concept of this N-S Link has been under development by both companies for a number of years. The technology envisaged for these two new circuits is single circuit 400 kV alternating current (AC) overhead line.
15. Overhead line (OHL) has been the standard transmission technology around the world for many years, simply because it has been the lowest cost option by some margin, and is also, all else being equal, the quickest to construct. However, feasible alternatives to OHL do exist for some transmission applications, and so, in 2008, EirGrid and NIE jointly commissioned Parsons Brinckerhoff to consider the alternatives to 400 kV AC OHL for the N-S Link. The requirement was (i) to establish whether an underground solution to the Tyrone-Cavan-Meath transmission requirement was viable from the technical and landscape viewpoints, and (ii) to estimate comparative costs for overhead and underground options, both AC and high voltage direct current (HVDC). The results of this study, which included on-site assessments as well as desk-top review by technical specialists, was reported in February 2009 – see Bibliography reference (1), and is referred to in this document as the ‘2009 Report’.

1.2 The Need for this Update

16. In both NI and the RoI there remains the need to make available the results of the Parsons Brinckerhoff study to public scrutiny. In Northern Ireland, NIE’s application for planning consent for the NI section of the proposed N-S Link triggered a Public Inquiry in the first quarter of 2012, however this Public Inquiry was subsequently suspended. NIE is now making preparations to resume the planning application, and therefore requires an update of the supporting technical evidence.
17. In the RoI, EirGrid had submitted an application for planning approval in December 2009. This application came to an oral hearing before An Bord Pleanála in May 2010, but was subsequently withdrawn in June 2010. The consideration of the technical alternatives section of the Environmental Impact Statement (EIS) associated with that planning application placed considerable reliance on the findings of the 2009 Report and, since EirGrid intends to submit a revised planning application, they are preparing a new EIS which requires up to date information.
18. In 2011 an International Expert Commission (RoI IEC) was set up by the RoI Minister for Energy, Pat Rabbitte, to review the N-S Link proposals and studies associated with them. The report of the RoI IEC, referred to in this Addendum as the RoI IEC 2011 Review, was published in January 2012 – see Bibliography reference (2).
19. Amongst the previously published technical reports considered by the RoI IEC 2011 Review was the Parsons Brinckerhoff 2009 Report. The RoI IEC concluded, in reference to that report, that “the results are correct and the analysis is very robust. However, today the

results may be different both in cost and technical performance given the recent technological developments”.

20. In order to pursue their planning applications, therefore, NIE and EirGrid require an update of the technical options and cost estimates for the N-S Link. They have thus requested Parsons Brinckerhoff to update the cost element of their 2009 Report in the light of any recent technical developments. This present document reports the results of that task.

1.3 Scope of Work

21. The scope of work comprises updating the cost estimates provided in the 2009 Report, and extends to taking into account the possibility that new technology might offer cheaper solutions than were previously available. Most of the technical and landscape, aspects of the 2009 Report have not been revisited, however. In particular, the functional requirements of the N-S Link (for example, running voltage, transmission capacity) are assumed here to be unaltered from 2009.
22. This current document should thus be considered an addendum to the original 2009 Report, and should be read in conjunction with it to obtain a full understanding of the considerations upon which it is based. Accordingly, within the text that follows, this document will be referred to as the ‘Addendum’.
23. We have been asked to present the cost updates in a single currency – namely Euros.
24. Part of the scope of work for this Addendum was to address the RoI IEC’s comments which were pertinent to the 2009 Report. These comments are presented in Appendix A of this Addendum, and references to the body of the text are made there, as appropriate. We note here, however, that whilst the RoI IEC recommended against a fully undergrounded AC solution for system technical reasons, a fully undergrounded AC solution has nevertheless been costed in this addendum in the interests of completeness and to assist any consideration of partial undergrounding of the route.

1.4 Which Costs?

25. The aim of the study is to estimate the differences in cost between the transmission circuit technology alternatives – for example, the cost difference between OHL and underground cables (UGC). In the interests of simplifying like-for-like comparisons, we have included in our estimates the costs of appropriate designs of transformer and switchgear where these differ between technology options, although we have not included elements of the project that are common to all technology options, and we have not extended the estimates to cover payments to landowners – see Footnote ¹.
26. Our approach to these connection costs applies equally to AC and to HVDC transmission technology. The latter requires dedicated converter stations to be placed between the HVDC and the AC elements of the transmission network, so converter station costs are also included in our estimates.
27. We have summarised the above approach for each type of technology (overhead AC, underground AC, and underground HVDC) in a series of single line diagrams, each of which is placed at the start of its relevant section. Figure 1, on Page 16, focuses on the overhead line option, whilst Figure 2, Page 21, and Figure 3, Page 33 cover the underground AC cable

¹ Payments to directly impacted landowners – for example purchase of rights of way or easements, compensation for loss of development rights or forestry rights, or flexibility payments agreed with farming representative bodies – are very site-specific, and so are not included in our estimates.

and the underground HVDC cable options respectively. In each of these diagrams we have shown firstly, in red, the equipment we have costed, and secondly in blue, other equipment common to all technology options which has thus not been costed.

1.5 Information Sources

28. In February 2012 the UK Department of Energy and Climate Change (DECC) published a Parsons Brinckerhoff Electricity Transmission Costing Study, whose primary purpose was to provide British planning officers and other stakeholders in UK transmission construction plans with a robust, independent comparison of transmission technology costs. This document is freely available for download from the Institution of Engineering and Technology website – see Bibliography reference (3) and forms the basis of many of the cost estimates in this report. It is referred to in this document as the DECC Costing Study.
29. Where appropriate information is not available from the DECC Costing Study, Parsons Brinckerhoff transmission specialists have made their own estimates based upon information from recent contracts, tempered with their own experience.
30. In all cases we present here second half 2012 costs, with cost information being adjusted, as appropriate, with British Electrotechnical and Allied Manufacturers' Association (BEAMA) price indices.

1.6 Content of this Addendum

31. This report comprises the following sections:
 - i This present Introduction,
 - ii A brief overview of technology changes since 2009 that could have a significant impact on transmission cost estimates for the N-S link,
 - iii Updated cost estimate tables for Chapter 8 of the 2009 Report,
 - iv Updated cost estimate text and table for Chapter 9 of the 2009 Report,
 - v A bibliography of referenced information sources, and
 - vi A list of acronyms used, and their meanings.

1.7 Format of the Cost Estimate Tables

32. To facilitate “read-across” of the updated tables into the original 2009 Report, each of the Chapter 8 tables is presented here in the same format as in the 2009 Report. There is one general exception to this, however. As requested, we have restricted the estimates tables to contain costs in Euros (€) only.

2 RECENT TRANSMISSION TECHNOLOGY CHANGES

2.1 General

33. The essence of electricity transmission is to provide efficient and economic paths for the flow of electric current (conductors) whilst at the same time providing safety from the high voltage for those nearby. Whichever technology is employed, transmission is a complex task, so there are a number of aspects where designers could seek to make improvements. We identify here three design improvements over the last four years which could affect transmission cost estimates for the proposed N-S Link. These are now described in turn.

2.2 Overhead Lines – No Significant Technical Changes

34. Many transmission companies around the world are facing increasing public pressure to find less visually intrusive transmission technologies than the traditional OHL supported by steel lattice towers. Architecturally designed alternatives proliferate, however, few, to date have been proven to achieve the rigorous strength, performance, and maintenance requirements.
35. Aside from these architecturally triggered developments (which are as likely to increase OHL costs as to decrease them) we are not aware of any recent technical advances in OHL technology that would significantly affect the cost estimates, and so our cost estimates are again based upon the use of the “IVI-type” single circuit steel lattice towers.

2.3 Underground Cables – Improved Backfill, and Higher DC Voltages

36. Current designs for new AC transmission voltage UGC most frequently adopt cross-linked polyethylene (XLPE) insulation, and this is the type that was assumed for the 2009 Report. Cable designs themselves have not changed fundamentally since then, however new options for cable trench backfill – the material which surrounds the cables at the bottom of the cable trench – offer limited potential to reduce the capital cost of the cable itself.
37. Cables are traditionally laid within cement-bound-sand (CBS) to stabilise their temperatures under a wide variety of operating conditions. Though CBS is not, itself, particularly good at heat dissipation, it is a relatively cheap solution to the issue of thermal stability. However, newer materials, with improved thermal conductivity, are now available for this purpose, and in some circumstances this allows for a lower cost cable to be installed. An example of this backfill material is ThermoCem® Plus.
38. Since the new cable backfill materials are more costly than CBS, each application requires its own assessment regarding the comparative cost benefit of the CBS option and the alternatives.
39. In the case of underground cable for the proposed 135 km N-S Link, the project could see marginal financial benefits from an improved backfill, though a small fluctuation in cable material prices can overwhelm the financial benefits of improved backfill material. Thus, whilst recognising here the existence of improved backfill materials, we have not sought to influence our cost estimates either way on account of their availability.
40. Regarding HVDC cable voltages, steady development in HVDC cable designs now makes the use of +/- 320 kV HVDC cables commercially feasible. Higher voltages still are mooted for the future, but at this stage these do not offer a commercial prospect to the N-S Link.

2.4 HVDC – VSC Designs

2.4.1 Technical Improvements

41. For many years HVDC technology has been available for electricity transmission, though its use is restricted to applications where its higher cost is specifically justified. Special converter stations, or terminals, connect HVDC circuits to the rest of the AC transmission network, and it is these converter stations, that represent the majority of the cost.
42. Operational limitations imposed by the “classic” current-sourced-converter (CSC, line commutated converter, LCC) designs comprise the other reason why HVDC transmission has not been used routinely. Nevertheless, this design of HVDC has offered cost and / or technical benefits in three main areas:
 - i. Transmission over very long distances over land,
 - ii. Transmission undersea, where distances exceed around 80 km, and
 - iii. Transmission between two systems with differing AC frequencies.
43. It was this classic CSC converter technology that was reviewed in the N-S Link 2009 Report.
44. Whilst the classic CSC technology was briefly reviewed in the 2009 Report, this option would not have offered serious competition to the AC alternatives from the point of view of system flexibility and security – its principle advantage being the efficient transport of bulk supplies over long distances. It has thus not been further reviewed in this Addendum.
45. Recent advances in converter technology have been adding to the advantages that may be offered by HVDC. The new voltage sourced converter (VSC) designs offer a number of extra advantages including:
 - i. The potential to offer stabilising and reactive power services to the AC network(s) to which they are connected, and
 - ii. The ability to offer black start capability at either end.
46. When comparing VSC with CSC, the following additional advantages are available from VSC:
 - i. Smaller footprint on the ground (only about 40% land-take is required when compared to the same transmission capacity CSC),
 - ii. The ability to quickly change the direction of flow of power without requiring a reversal of the direct current polarity,
 - iii. Improved stability of the HVDC link operation, particularly when connected to electrically weak and isolated AC networks (such as can exist on the island of Ireland),
 - iv. The option of using lighter construction polymeric cables, as a result of the absence of polarity reversal, which allows longer cable sections between joints, and
 - v. The better facilitation of multi-terminal working – that is to say, the possibility of making a connection (or more than one) part way along the overall HVDC circuit.
47. On the other hand, significant disadvantages to VSC designs, in comparison with CSC alternatives have, in the past, included:
 - i. relatively low transmission capacity,
 - ii. poor operating efficiencies, and

- iii. higher capital and operating costs per MW capacity, and
 - iv. limited overload capability.
48. Disadvantages i and iii remain relevant today, though market pressures are reducing their significance gradually. The VSC converter operating efficiencies mentioned in item ii are now around 99%, so approaching those of CSC designs, which currently stand at about 99.25%. (Note: Each VSC converter station typically exhibits around 1% losses at full load, so a three terminal link such as would be required for the N-S Link would incur up to 3% converter losses plus the losses from the overhead lines or underground cables.)

Future Availability of 1500 MW VSC Converters

49. Although VSC converter maximum capacities lag significantly behind those of CSC, designs continue to improve. The largest VSC installation currently in operation is EirGrid's 500 MW East-West Interconnector (the +/- 200 kV subsea interconnector connection between Woodlands Substation, Meath, and Connah's Quay Substation, UK). However, a 1000 MW +/- 300 kV bipole design is due to be commissioned between France and Spain in 2013, and a 715 MW 500 kV monopole converter is to be commissioned between Norway and Denmark in 2014 – see Bibliography references (4) and (5), and also the Footnote². We anticipate that 1500 MW bipole VSC designs – that is, converters that match the capacity specified for the proposed N-S Link – are thus likely to be commercially available by around 2016.

2.4.2 Future Availability of HVDC Circuit Breakers

50. Circuit breakers allow immediate disconnection between two operational parts of an electricity power network. Whilst this function is most normally used to configure the network to normal running conditions, and to disconnect sections of the network for planned maintenance, circuit breakers are also essential in the process of isolating faulted circuits quickly enough to protect personnel and equipment whilst maintaining the overall stability of the power supply.
51. AC circuit breakers have been available for many years but, at the time of writing, commercially available high voltage transmission circuit breakers for HVDC do not exist. The Rol's International Expert Commission (RoI IEC) has forecast that HVDC circuit breakers will become commercially available by 2013. This prediction is coming to pass in a limited way; more than one HVDC equipment supplier has announced the existence of a design for an HVDC circuit breaker.
52. In practice, however, the specification, availability, and costs, of these devices are either still obscure, or not developed. There is no track record of a practical transmission device operating in a commercial environment, and we note that confidence in their imminent arrival for commercial operation is low. Indeed, transmission connections are being planned on the assumption that such equipment will still not be available by 2019.
53. This being the case, at present it is impractical to provide an HVDC network (with more than two terminals) with the same operational flexibility as an AC equivalent. Our view, therefore, is that NIE and EirGrid's plans should assume that HVDC circuit breakers would not be available for the N-S Link project, and to plan a system that does not require them. Given the developers' recent announcements, however, in the event that an HVDC solution is chosen for the N-S Link, a design which allowed for retrofitting of HVDC breakers in the medium to long-term (as, for example, the USA's Tres Amigas project) may be considered appropriate.

² This particular VSC installation, at Skagerrak, is due to be configured as 'pole (4)', operating as half of a bi-pole with the existing LCC (CSC) pole (3). We understand that the switchgear arrangements will be complex, to allow for reverse power flow. As such, it would represent a 'one off' solution rather than a template for future schemes.

2.4.3 Implications of a Single Tyrone – Meath HVDC Circuit

54. With the classic CSC HVDC technology, it was assumed in 2009 that the N-S Link would have comprised two separate circuits – Tyrone-Cavan and Cavan-Meath – requiring a total of 4 converter stations. With the newer VSC solution, however, there is the option to build a single Tyrone-Meath circuit, with an HVDC “tee-off” connection for Cavan – thus requiring only 3 converter stations.
55. There are a number of pros and cons to a three-terminal solution. Benefits include:
- i. Less ground space required for the middle connection in Cavan, and
 - ii. a significant capital cost saving over the 4-converter CSC option, for the Cavan connection.
56. Disadvantages of the three-terminal solution can include:
- i. lower operational flexibility for Cavan connectees (a single converter outage at Cavan – planned or unplanned) would leave generation and load customers connected at Cavan zero (or 50%) access to the N-S Link (depending on whether a fully rated neutral connection is installed alongside the +/- pole connections),
 - ii. depending upon the connection configuration at Cavan, lower partial availability of the N-S Link (some equipment failures would cause non-scheduled outages for the entire link), and
 - iii. lower system security (non-scheduled outages of the entire link are likely to have greater impact on the overall system security than non-scheduled outages of half of the link, so again, a bipole installation with neutral connection would be the preference operationally).
57. These operational disadvantages could be mitigated with high-speed off-line segmentation of the HVDC circuit, which would allow two of the three sections of the HVDC connection to return to service after the faulted section had been isolated. Since the whole purpose of the N-S Link would be to strengthen and secure the Irish transmission network, such a segmentation facility could be a prudent and important part of a practical HVDC solution, which would lift the level of operational facilities closer to that of the AC options. In the interests of comparing like with like, we have thus included HVDC circuit selector facilities in the costs for the HVDC option. We note however that the selectors would comprise high-speed off-line HVDC devices, for which tried and tested technology already exists, rather than HVDC on-line circuit breakers. We have assumed this facility would be located coincident with the Kingscourt HVDC converter.
58. Since a 3-terminal solution is likely to be of significantly lower cost than a 4-terminal solution, for the purposes of this update we have costed the three-terminal option, with high-speed off-line circuit segmentation as depicted in Figure 3, Page 33.
59. Whether a 3- or 4- terminal solution was adopted, a “Special Protection Scheme” would be required across the all-island transmission network to fully integrate the HVDC interconnector. Detailed studies would be required to ascertain the fault scenarios with significant impact on the island system, and the occurrence of each of these would need to be signalled back to the 3 HVDC terminals to trigger automatic responses to avoid system instability. Indicative cost estimates relating to these studies and facilities are incorporated in this Addendum, although it is important to realise that only detailed Electrotechnical studies would be able to identify the full extent of the requirement.

2.4.4 Relevance of East-West Interconnector Infrastructure

60. The question has been asked: "What advantages could there be for a future HVDC N-S Link from the existing HVDC E-W Interconnector?". Two notional benefits perceived by proponents of this approach are:
 - i. Sharing converter equipment between the two installations, to save on capital cost, and
 - ii. Direct connection through Woodlands Substation at HVDC, to save on operational cost associated with electrical losses.
61. Briefly explained, the E-W Interconnector comprises a 500 MW VSC link from Woodlands Substation, Meath, to Deeside Substation, UK, which operates at +/- 200 kV (for further details, see, for example, Bibliography reference (6)). Since there is already a 500 MW converter at Woodland Substation, the first benefit sought would be that this converter, together with a new 1000 MW converter, would provide the 1500 MW capacity required for the N-S Link, thus achieving capital cost savings over the construction of a 1500 MW terminal.
62. At the same time, connecting together the HVDC conductors for the N-S Link and the E-W Interconnector would allow power not required at the Woodland AC substation to pass straight through between N-S and E-W, avoiding the double conversion energy losses for power transmitted from HVDC to AC, and back again to HVDC (around 3% energy losses: 2% from the older E-W Interconnector, and 1% from a new N-S link). This should deliver operational savings, as mentioned above.
63. To achieve these benefits, the proposed N-S Link would need to be of VSC design, and would need to operate at the same HVDC voltage as the E-W Interconnector. At the time of writing, the design voltage of a future 1500 MW VSC link is uncertain, but 1000 MW links currently on order for Europe (see paragraph 49 above) will operate at +/-320 kV – that is, at significantly higher voltages than the E-W Interconnector. We believe it to be extremely unlikely that a 1500 MW design could compromise on operating voltage adequately to allow successful connection to the E-W Interconnector.
64. A further technical factor comes into play when two HVDC installations are connected together – namely fault levels. Direct connection of a new N-S Link to the E-W Interconnector at HVDC would tend to impose excessive fault levels on the existing equipment. Matching N-S Link fault levels to those of the existing equipment would almost certainly significantly compromise the operation of the new transmission plant.
65. Against these disadvantages, the capital and operational savings of installing a 1000 MW converter at Woodlands, instead of a 1500 MW might, on present estimates, amount to some tens of millions of Euros. However, this financial benefit would have to be set against:
 - i. the operational risks of devising a unique running regime,
 - ii. the costs of overcoming the voltage and fault level issues mentioned above, and
 - iii. the costs of re-engineering the control systems on the existing E-W Interconnector.
66. Further consideration of the technical factors associated with a N-S Link / E-W Interconnector connection at HVDC is beyond the scope of this report but, given the technical disadvantages mentioned above, we consider it extremely unlikely that any cost-reducing synergy would be found between the existing E-W Interconnector and the proposed N-S Link.

2.4.5 Summary of Position on HVDC Technology

67. Given all the above considerations, we cannot see any benefit to Ireland of rejuvenating reviews of the classic CSC (LCC) HVDC. However, with current state of development of VSC technology, and given the further VSC developments expected in the near future, we do consider it appropriate to review potential VSC costs alongside those of AC technologies.
68. HVDC circuit breakers of the capacity required for the N-S Link are not expected to become commercially available in the near term, and their availability should not be assumed for the N-S Link. As an alternative to HVDC circuit breakers, auto-disconnector technology (similar in concept to the auto-reclose cycle widely used on AC networks) could offer short-term system performance inferior to, but of the same order as, the AC alternatives.
69. With VSC technology, a N-S Link could, by around 2016, comprise either two circuits linked via the AC network at Cavan, or a single direct Tyrone – Meath circuit with a Cavan tee-off. We have estimated costs for the latter, this requiring three, rather than four, terminals, and thus offering the lower cost HVDC option.
70. It is theoretically possible to connect the proposed N-S Link to the existing E-W Interconnector on the HVDC side, but the design limitations are likely to be very substantial. On the initial view developed here, it seems probable that the financial benefits anticipated in 65 above would be outweighed by the limitations.

3 THE CHAPTER 8 COST TABLES AND PARAGRAPHS

3.1 General

71. This chapter contains updates for the tables and text of the 2009 Report which refer to costs. No attempt is made to repeat, or update, other information or lines of argument here; the 2009 Report itself provides the context of these cost estimates.
72. What this report does do, however, is to update transmission costs on the basis of current technology, rather than that which prevailed during the preparation of the 2009 Report. Further detail on the changes in technology since that time may be found in Section 2 above.

3.2 Costing Assumptions and Approximations

73. Rounding: Costing estimates presented in the following tables are rounded as appropriate; however, the calculations behind the tables are not rounded. This approach preserves the integrity of the calculations themselves; however it can cause an apparent discrepancy between last significant digits of associated numbers. The conclusions of this report are never affected by such rounding discrepancies.
74. Equipment design life: Transmission equipment is often specified to have an operational life of 40 years or more. Actual equipment life will vary not only with its design, but with the maintenance / overall regime and with the system and environmental conditions in which it operates. We have assumed a 40-year life.
75. Cost base: Transmission costs presented in this Addendum are 1st quarter 2013 estimates.
76. Foreign exchange rates: Transmission equipment may be sourced from many places around the world so the information we have used to estimate costs has originated from more than one currency base. In addition, some commodities are traditionally quoted in a particular currency so, for example, overhead line tower steel prices are frequently quoted in US dollars (USD). Of course, the rates continue to change daily, however the set we have used for the present estimates are:-

Currencies	Exchange Rate
EUR/GBP	1.208
USD/GBP	1.613

77. Currency basis: The 2009 Report was originally commissioned by EirGrid and, though NIE subsequently took on the role of principal client for the study, for comparison purposes the transmission costs were all placed on a euro (EUR) basis, and then key costs were converted to pounds sterling (GBP) with then-prevailing exchange rate. On this occasion, however, even though the update has been commissioned by NIE, we have been requested to present the costs in a single currency, that being EUR.
78. Exchange rate volatility: At the time the 2009 Report was in preparation, exchange rates were much more volatile than recently. For example, in the last quarter of 2008 the number of euros to the pound dropped by nearly 20% (a change rate of around 2% per week), whilst in the last 6 weeks of 2008 USD/GBP rate also moved at around 2% per week – but in the opposite direction. In comparison, over the last 12 months neither exchange rate has varied by more than around 9% (EUR/GBP) and 5% (USD/GBP) in total. (Source: Oanda – average weekly bid rates.) The above exchange rate factors render it inappropriate to make close comparisons between the 2009 and the current cost estimates.

79. Construction Costs: For the purposes of estimating whole-of-life costs, construction costs are deemed here to include a notional interest during construction (IDC) sum. (Calculation of IDC is described in the 2009 Report.)
80. Operation Costs: Operational costs comprise, in these estimates, the sum of:
- i. The cost of the annual energy losses from the transmission circuit,
 - ii. The annualised cost of the power losses to the system, and
 - iii. The annual operation and maintenance (O&M) costs.
81. Discounted Cash Flow Calculation: Construction and operation costs are calculated on a discounted cash flow basis (DCF), using the annual discount rate declared in Table 8-21, page 30 of this document. This figure (8.1%) is the average of the weighted average cost of capital (WACC) for the UK and the RoI (6.41% and 9.74% respectively), and is declared in Table 7.3, p25, of the CER document AIP/SEM/12/078 – see Bibliography reference (7). (Further description of the DCF calculations may be found in Section 8.1 of the 2009 Report.)
82. Losses: Technical losses, which contribute to the lifetime operational costs, have been estimated from the electrical characteristics of the overhead line, underground cable, and HVDC converters whose costs have been estimated in this document. They are based upon an average circuit loading of 34% capacity - 500 MW. This assumption, along with the magnitudes of energy and power losses for overhead lines and underground cables, are assumed unchanged from the 2009 Report. The losses assumed for the HVDC converters have been newly calculated for the conditions of this assessment.
83. Energy Losses Cost: The costs of whole-of-life energy loss costs are based upon a short-run marginal cost (SRMC) of €60.66 / MWh. This figure has been derived from the average system marginal price for Ireland over the last five years or so, which was sourced from a spreadsheet – see Footnote ³ – published on the website of the Single Electricity Market Operator for Ireland (SEMO) – see Bibliography reference (8). (Further description of energy losses calculations may be found in Appendix D of the DECC Costing Study.)
84. Power Losses Cost: The costs of whole-of-life power loss costs are based upon the long-run marginal cost (LRMC) of best new entrant (BNE) Peaker plant in Table 11.1, p45, of the 2012 publication AIP/SEM/12/078 by the Irish Utility Regulator, the Commission for Energy Regulation (CER) – see Bibliography reference (7). We adjust the BNE Peaker figure (€78.18 / kW pa) to take account of associated transmission capacity. (Further description of power losses calculations may be found in Appendix D of the DECC Costing Study.)
85. Other whole-of-life costs: Maintenance costs are estimated as a percentage of the capital costs of equipment – see Table 8-21, on page 30 of this document.
86. Estimate Range: Given the above assumptions and considerations, we describe all the costs in this section as ‘central estimates’, with a working variance of +/- 20% for planning purposes.

³ SEMO System Marginal Price (EP2) from 11Dec07-18Feb13 is published on the SEMO website, under their General Publications – System marginal Price For All Gates in a file called SMP2007-2013.xls. (“EP2” denotes “Ex-Post Initial MSP Software Runs (including subsequent Settlement Reruns)”, which we estimate to be adequately stable for deriving SRMC.

3.3 Section 8.3 HVAC OHL Costs: Table 8-1 – Table 8-4

87. The equipment costed for the overhead line technology option comprises (i) one single circuit 400 kV overhead line from Turleenan to Kingscourt, and (ii) a further 400 kV overhead line from Kingscourt to Woodland. At Turleenan and at Kingscourt no 400 kV connection points currently exist so, to make the technology alternatives as comparable as possible (and unlike the previous estimates) this time we have also costed, (iii) for each of these two locations, two 500 MVA transformers along with associated switchgear and connections – see Footnote ⁴. Finally, at Woodland, where 400 kV connections already exist, for the same reason we have costed (iv) switchgear (one circuit breaker bay) and associated connections.
88. The equipment we have costed is shown in red in the following diagram.

Figure 1 - Costed and Non-Costed Equipment – the Overhead Line Option

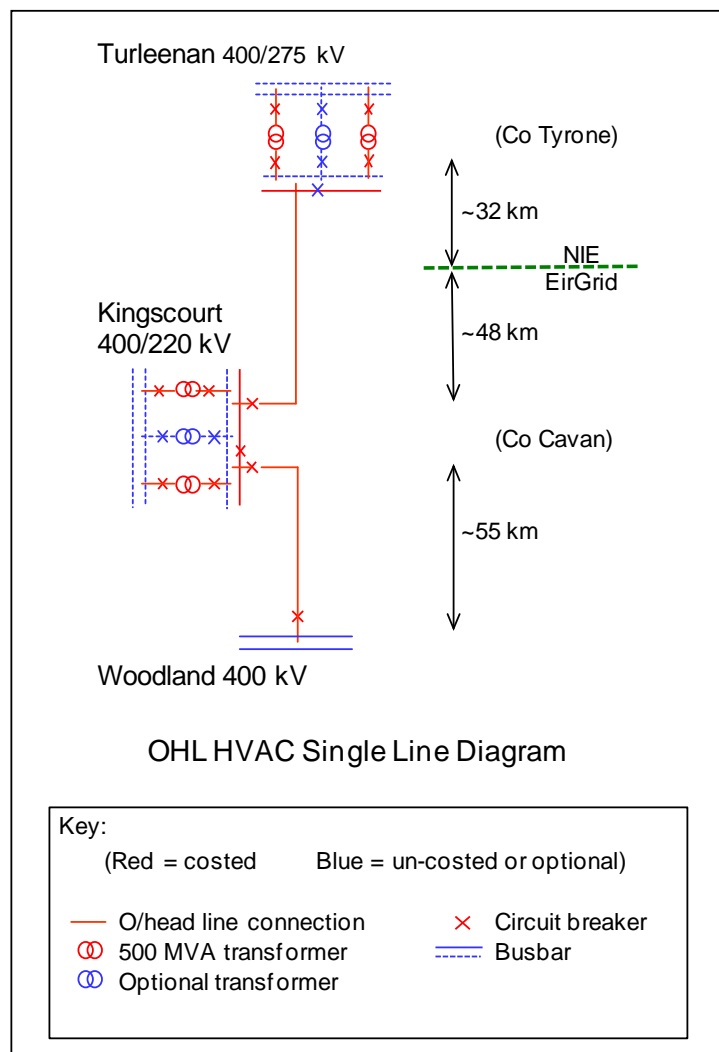

Source: Parsons Brinckerhoff - see Section 1.4 for further details.

⁴ Switchgear costs are mentioned in paragraph 25, and further detail is provided in Section 3.6, Page 39. Switchgear costs are added into the final cost comparisons in Section 4, Table 9-1 on Page 41.

3.3.1 Assumptions

89. In the OHL costs tables we make the following key assumptions:
- i. Construction costs are based upon those of the DECC Costing Study, but have been adjusted for the twin bundle ACSR (aluminium conductor steel reinforced) Curlew phase conductor of the proposed N-S Link OHL. Construction project launch and management fees are 10% of the capital costs of the OHL materials, erection, tower foundations and site access costs.
 - ii. Overall build contingency comprises an additional 10% of the estimated OHL capital costs.
 - iii. We assume that two transformers would be installed at Turleenan and Kingscourt in the first instance, for system security and maintenance purposes. We believe it is unlikely that three transformers would be needed immediately at either of these two sites since, although 3 x 500 MVA units would be required there to achieve the full specified 1500 MVA transmission capacity, it seems probable that two transformers at each site would provide adequate capacity for some years. For this reason, costs for these third transformers are not included in the main cost estimate tables.
 - iv. Losses costs are based upon the proposed twin bundle Curlew conductor, and upon an average circuit loading factor of 34%, as in 2009. Whilst the technical losses are assumed unaltered, the costs of these losses are updated as described in the three paragraphs starting at Paragraph 82, Page 15.

3.3.2 The Tables

90. The following tables incorporate our cost estimate updates for the overhead lines tables in the 2009 Report. The first table, Table 3.2, re-states physical parameters that were used to calculate losses.

Table 3-2, p28 – Assumptions for losses calculations

Power factor:	unity		
System voltage:	400kV		
Parameters per phase / pole:-	AC OHL - twin Curlew (2x600 mm ² ACSR)	AC UGC (1x1200 mm ² aluminium XLPE)	HVDC UGC (1x1600 mm ² aluminium XLPE)
R (ohms / km)	0.03	0.025	0.021
X (ohms / km)	0.13	0.24	
B (microsiemens / km)	4.4	57	
Other parameter assumptions are to be found in Table 8-5.			

Table 8-1, p95 – Unit Costs of HVAC OHL

	€k / km	% of Total
Materials	250	28%
Time (Contractor)	460	50%
Other costs	50	5%
Engineering & Project Management	70	8%
Supply Total	830	91%
OHL Supply Contingency @ 10% (see text)	80	9%
Supply Total estimate, inc. Contingency	920	100%
Land Access Management, incl. land owner compensation	(Beyond scope of report)	
PB estimate- lower	740	80%
PB estimate- upper	1100	120%

Source: DECC Costing Study

T8-1

91. The proportion of cost against the contractor's time reflects the increasing expectation of effort to accommodate safety and environmental requirements before construction can begin. Note – this Table 8-1 does not include interest during construction (IDC), however IDC will be found in Table 8-4.

Table 8-2, p96 – OHL Lengths and Cost Estimates

OHL Route Section Length Estimates (km)			
Meath-Cavan, EirGrid	Cavan-Tyrone, EirGrid	Cavan-Tyrone, NIE	Whole Route
52.9	44.7	30.7	128.2

Source: Parsons Brinckerhoff 2009 Report Table 8-2

Note: The above distances are used to allow like-for-like comparison of OHL and UGC costs, and should not be taken to represent a particular route.

OHL Route Section Cost Estimates					
Units	Overall OHL Unit cost	Meath-Cavan, EirGrid	Cavan-Tyrone, EirGrid	Cavan-Tyrone, NIE	Whole Route
€M	0.9/km	49	41	28	118

Source: This Addendum Table 8-1

T8-2

Table 8-3, p96 – OHL Maintenance Costs

O&M – OHL (% of capital value per annum) = 0.2%

Table 8-4, p98 – OHL Discounted Cash Flow – Lifetime Costs Example

The table presented here is an augmented version of that presented in the 2009 Report. Extra columns are provided to allow present values to be seen separately for interest during construction, end of life replacement and operating costs. Discount rate is 8.1%:

OHL - 400kV "I-V-I" towers - 600sqmm Curlew ACSR - 2 Condr/phase - 500MW Load											
Year	Electrical Losses		Costs (€M)								
	Energy Losses (GWh.pa)	Power losses (MW)	Circuit Construction Capital	IDC	Total Construction + IDC	End-of-life Replacement	Annual Energy Losses	Annualised Power Losses	Annual O&M	Total Operating Costs	Total Cashflow
1			59.0	2.4	61.4						61.4
2			59.0	7.2	66.2						66.2
3	54.6	13.9					3.3	1.4	0.2	5.0	5.0
4	54.6	13.9					3.3	1.4	0.2	5.0	5.0
5	54.6	13.9					3.3	1.4	0.2	5.0	5.0
39	54.6	13.9					3.3	1.4	0.2	5.0	5.0
40	54.6	13.9				134	3.3	1.4	0.2	5.0	139
Totals	2,075		118	10	128	134	126	54	9	189	450
40 year PV (€M)			114	9	123	6	36	15	3	54	183

Sources: Various - see N-S Link 2009 text.

T8-4

Note – in the above table, acronyms have the following meanings:

- OHL – overhead line
- IVI – name for the overhead line tower type selected by NIE and EirGrid
- ACSR – aluminium conductor, steel reinforced (a conductor type)
- MW – megawatts
- GWh.pa – gigawatt hours per annum
- IDC – interest during construction
- O&M – operations and maintenance
- PV – present value (of a series of costs over time)

3.4 Section 8.4 HVAC UGC Costs: Table 8-5 – Table 8-22

92. The equipment costed for the underground cable technology option comprises (i) a double circuit 400 kV cable from Turleenan to Kingscourt, and (ii) a further double circuit 400 kV cable from Kingscourt to Woodland – see Paragraph 94 for an explanation of the double circuit arrangement. As for the overhead line option, (see Page 16 for further explanation) we have also costed, for each of Turleenan and Kingscourt, (iii) two 500 MVA transformers along with associated connections and switchgear. At Woodland we have costed (iv) two circuit breakers and associated busbar bay equipment and installation procedures. Finally, to accommodate the underground cable in the existing AC network, we have costed (v) reactive compensation at each substation and at three intermediate locations along the cable route, as noted in Figure 2. (This mirrors our reactive compensation assumptions in the 2009 Report.)
93. The costed equipment is indicated in red in the following diagram.

Figure 2 - Costed and Non-Costed Equipment – the Underground Cable Option

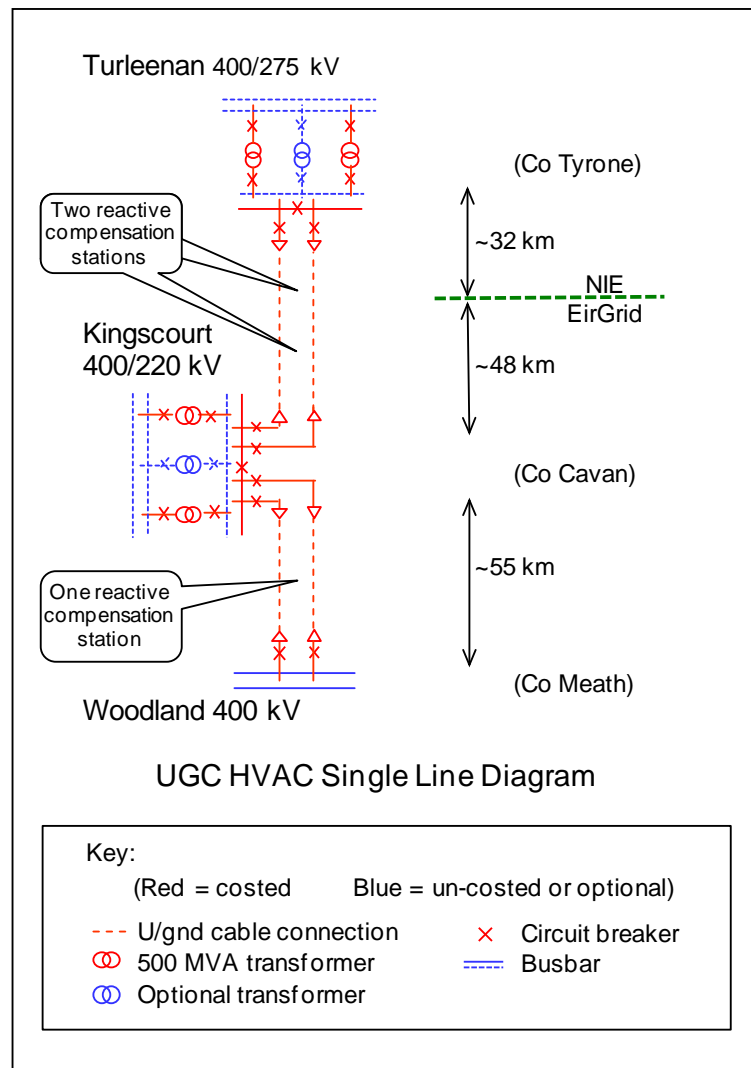

Source: Parsons Brinckerhoff - see Section 1.4 for further details.

94. The circuit layout shown in Figure 2 for the underground cable option is more complex than that for the overhead line because, although only a single transmission circuit is required, 2 cable cores would be required for each electrical connection (referred to as “two-cores-per-phase”) in order to provide adequate transmission capacity.
95. We have assumed that operational benefit would be taken from this necessary extra physical complexity by investing a little extra in switchgear to keep the two cores electrically separate. Such an arrangement would result in significant improvements in system security, and in availability during maintenance. The extra cost for this arrangement (which is effectively two circuits, each with half the required total transmission capacity) would be that of the extra switchgear and associated civils, controls and protection at the three substations – estimated at around €5.1M installed. Whilst this adds some 0.5% to the costs for the underground AC cable option, it should overcome to a great extent the transmission system operator’s concerns regarding the poorer availability for service of UGC compared to OHL.

3.4.1 Assumptions

96. In the UGC costs tables we make the following additional key assumptions:
- i. Construction costs are based upon those of the DECC Costing Study, but indexed to the current period using BEAMA labour and equipment price indices. An adjustment has also been made to take account of the use of aluminium rather than copper conductor cables.
 - ii. The 135 km of underground cable would require substantial reactive compensation, and the same configuration has been assumed as for the 2009 Report – namely dynamic compensation (for example, static var compensators or statcoms) at each of the substations, and passive compensation (shunt reactors) at three intermediate stations. The 2009 Report designs and costs have been adopted here, but indexed to the current period using BEAMA labour and equipment price indices.
 - iii. Special construction costs (for example, river and motorway crossings) are estimated half those of the DECC allowance, since there would be fewer such crossings per km in Ireland than assumed in the DECC case study.
 - iv. Construction project launch and management costs – which include survey, route access, route accommodation, and other owner costs as well as contractor accommodation and management – are estimated at 15% of the capital costs of the reactive compensation and UGC materials, terminations, and installation costs.
 - v. Build contingency costs are estimated at 15% of the UGC capital costs, reflecting the greater uncertainty associated with underground works.
 - vi. Losses costs are based upon 400kV XLPE-insulated aluminium UGC, and upon an average circuit loading factor of 34%, as in 2009. Whilst the technical losses are assumed unaltered, the costs of these losses are updated as described in the three paragraphs starting at Paragraph 82, Page 15.

3.4.2 The Tables

97. The following tables incorporate our cost estimate updates for the underground cables tables in the 2009 Report.

Table 8-5, p99 – AC Cable Parameters: Assumptions

Voltage Rating:	400kV
Overall Capacity:	1500MVA continuous (2165 Amps per phase)
Number of cable cores per phase:	2 circuits, each 1 core per phase (therefore total of 6 phase cable cores)
Cable type:	1200 mm ² aluminium conductor, lead sheath
Method of burial	Direct burial, at 750mm centres spacing, and about 1000mm cover to ground level. The 2 sets of 3 phase cores to be buried in separate trenches spaced at 5000mm between centres (not ducted, except at crossings).
Loading for loss calculations	500MVA (as for OHL)
Other parameter assumptions are to be found in Table 3-2.	

Table 8-6, p101 – Civil Engineering – Preliminary Works Costs

Civil Preliminary Works and General Charges for Overall Route (not including contingency)	Estimate (€M)
Construction (including plant, equipment, mobilisation supervision for all suppliers)	4.4
Surveys, photographic & engineering records	1.2
Other (including security, storage, communications, welfare, reinstatement)	6.3
Total	12.0

Source: DECC Costing Study and 2009 Report

T8-6

Table 8-7, p101 – Civil Engineering – Preliminary Works Costs by Route Section

Civil Preliminary Works and General Charges for Overall Route, including contingency	Meath-Cavan - EirGrid - (€M)	Cavan-Tyrone - EirGrid - (€M)	Cavan-Tyrone - NIE - (€M)	Totals (€M)
1. Proportion of these charges apportioned to each section of the route	40%	35%	25%	100%
2. Apportioned charges :	4.8	4.2	3.0	12.0
3. Contingency for preliminary works & general charges @ 10%:	0.5	0.4	0.3	1.2
Totals for preliminary works & general charges	5.3	4.6	3.3	13.2

Source: Table 8-6 and 2009 Report

T8-7

Table 8-8, p102 – Civil Engineering – Estimated Costs per km

Schedule of UGC civil works per km rates, inc. contingency:	Unit cost (€M/km)	Contingency (%)	Unit cost including contingency (€M/km)
A. Trench Preparation: (including trenching, shuttering, backfilling and reinstating, but not cable-pulling):			
1. Landscape types 1 & 2 (cost per km)	1.38	15%	1.58
2. Landscape types except 1 & 2 (cost per km)	1.40	15%	1.61
B. Cable Installation - both landscape types:	0.54	10%	0.59

Source: DECC Costing Study and 2009 Report

T8-8

Table 8-9, p103 – Trenchless Crossings – Unit Cost

Directional drilling unit cost estimate (7 bores per metre):	(€/m)
Estimated cost per metre (1 x 250mm dia core)	0.65
so,	
Estimated cost per metre (7 x 250mm dia cores)	4.6
Geological uncertainty factor (30%), see 2009 Report, para 432	1.4
Total Estimated cost /m (7 cores) incl. uncertainty factor	5.9

Source: DECC Costing Study and 2009 Report

T8-9

Table 8-10, p103 – Special Civil Works Lump Sum Costs

Schedule of directional drilling costs:	Unit cost (€M)
1. Trenchless Crossing - Large River @ 150m	0.89
2. Trenchless Crossing - Medium River @ 70m	0.41
3. Trenchless Crossing - Road @ 40m	0.24
4. Trenchless Crossing - Motorway @ 70m	0.41

Source: DECC Costing Study and 2009 Report

T8-10

Table 8-11, p104 – Special Civil Works Lump-Sum Costs by Route Section

Numbers of crossings, by route section:	Meath-Cavan EirGrid	Cavan-Tyrone EirGrid	Cavan-Tyrone NIE	Totals
1. Trenchless Crossing - Large River @ 150m	2	0	1	3
2. Trenchless Crossing - Medium River @ 70m	22	15	11	48
3. Trenchless Crossing - Road @ 40m	5	6	4	15
4. Trenchless Crossing - Motorway @ 70m	2	1	0	3

Directional drilling costs, including contingency, by route section	Meath-Cavan - EirGrid - (€M)	Cavan-Tyrone - EirGrid - (€M)	Cavan-Tyrone - NIE - (€M)	Totals (€M)
1. Trenchless Crossing - Large River @ 150m	1.8	0.0	0.9	2.7
2. Trenchless Crossing - Medium River @ 70m	9.1	6.2	4.6	19.9
3. Trenchless Crossing - Road @ 40m	1.2	1.4	0.9	3.5
4. Trenchless Crossing - Motorway @ 70m	0.8	0.4	0.0	1.2
Totals	12.9	8.0	6.4	27.3
5. Contingency for underground crossings @ 15%:	1.9	1.2	1.0	4.1
Total costs of underground crossings	14.8	9.3	7.3	31.4

Source: DECC Costing Study and 2009 Report

T8-11

Table 8-12, p105 – Summary of Civil Works Lump-Sum Costs, by Route Section

Total special civil costs, including contingency by route section	Meath-Cavan - EirGrid - (€M)	Cavan-Tyrone - EirGrid - (€M)	Cavan-Tyrone - NIE - (€M)	Totals (€M)
1. Civil preliminary works and general charges:	5.3	4.6	3.3	13.2
2. Directional drilling:	14.8	9.3	7.3	31.4
Total special civil costs	20.1	13.9	10.6	44.6

Source: DECC Costing Study and 2009 Report

T8-12

Table 8-13, p107 – Intermediate Reactive Compensator Costs

See 'Reactive Compensation' in the following revised Table 8-16

Table 8-14, p108 – Static Var Compensator Costs

See 'Reactive Compensation' in the following revised Table 8-16

Table 8-15, p108 – Summary of Compensation Costs

See 'Reactive Compensation' in the following revised Table 8-16

Table 8-16, p109 – Underground Cable Unit Costs

UGC Cost per km estimates (including contingency)	Landscape types 1 & 2 (€M/km)	Landscape types except 1 & 2 (€M/km)	One-off costs per Overall Project (€M)
Civils:			
Civils preliminary and special works, including mobilisation & directional drilling			44.6
Trench civils	1.6	1.6	
Civil supply - cable terminations			0.2
civil installation - cable pulling	0.6	0.6	
Total civil works	2.2	2.2	44.8
Total civil works per km, inc. apportioned one-off costs	<u>2.5</u>	<u>2.5</u>	
Electrical:			
Cable electrical supply	2.7	2.7	included in per km rate
Cable electrical installation	0.4	0.4	
Total cable electrical works	3.1	3.2	0.0
Total cable electrical works per km	<u>3.1</u>	<u>3.2</u>	
Reactive Compensation:			
Intermediate reactive compensation			41.6
Cable-end reactive compensation			47.2
Total reactive compensation	0.0	0.0	88.9
Total reactive compensation apportioned per km	<u>0.7</u>	<u>0.7</u>	
Totals:			
Project management	included	Included	
Overall supply, install, and contingency unit rates, incl. project management, with one-off costs apportioned over total length of connection (135.3 km)	<u>6.3</u>	<u>6.4</u>	

Source: DECC Costing Study and 2009 Report

T8-16

Table 8-17, p110 – Terrain Types, Corridor Lengths, Lengths Allowances

Terrain Area	Note	Terrain Pattern	Minimum Route Length (m)	Corridor Section	UGC Length Allowance (%)	Adjusted Length (m)	Cumulative Adjusted Lengths (m)
1	S of Turleenen	2aa	3,552	Cavan-Tyrone, NIE	5%	3,730	
2		2a	5,291	Cavan-Tyrone, NIE	5%	5,556	
3	River Blackwater	RC1	150	Cavan-Tyrone, NIE	10%	165	
4		2aa	2,364	Cavan-Tyrone, NIE	5%	2,482	
5		2a	14,964	Cavan-Tyrone, NIE	5%	15,712	
6	N of Border	2	4,340	Cavan-Tyrone, NIE	3%	4,470	32,115
7	S of Border	2	4,003	Cavan-Tyrone, EirGrid	3%	4,123	
8		2ab	8,272	Cavan-Tyrone, EirGrid	10%	9,099	
9		2b	2,822	Cavan-Tyrone, EirGrid	10%	3,104	
10		2a	21,554	Cavan-Tyrone, EirGrid	5%	22,632	
11	N of Kingscourt	2b	8,013	Cavan-Tyrone, EirGrid	10%	8,814	47,772
12	S of Kingscourt	2b	2,800	Meath-Cavan, EirGrid	10%	3,080	
13		2bb	9,783	Meath-Cavan, EirGrid	10%	10,761	
14		1	11,711	Meath-Cavan, EirGrid	3%	12,062	
15	River Blackwater	RC2	150	Meath-Cavan, EirGrid	10%	165	
16		1	12,342	Meath-Cavan, EirGrid	3%	12,712	
17	River Boyne	RC3	150	Meath-Cavan, EirGrid	10%	165	
18	N of Woodland	1	15,967	Meath-Cavan, EirGrid	3%	16,446	55,392
Totals			128,228			135,279	135,279

Source: 2009 Report

Table 8-18, p111 – Terrain Pattern Lengths by Corridor Section

Terrain Pattern	Corridor Section length (km)			
	Meath-Cavan, EirGrid	Cavan-Tyrone, EirGrid	Cavan-Tyrone, NIE	Whole Route
1	41.6	-	-	41.6
2	-	4.1	4.5	8.6
2a	-	22.6	21.4	44.1
2aa	-	-	6.2	6.2
2ab	-	9.1	-	9.1
2b	3.1	11.9	-	15.0
2bb	10.8	-	-	10.8
Totals	55.4	47.8	32.1	135.3
	40%	35%	25%	100%

Source: N-S Link 2009 Report

T8-18

Table 8-19, p112 – Terrain Pattern, Drum Length and Unit Costs

Terrain Pattern	Drum Length (m)	UGC unit cost (€/km)
1	690	6.26
2	690	6.26
2a	625	6.38
2aa	625	6.38
2ab	625	6.38
2b	625	6.38
2bb	625	6.38

Source: DECC Costing Study

T8-19

Table 8-20, p112 – UGC Installed Costs, by Corridor Section

Terrain Pattern	Overall Unit cost (€M/km)	Corridor Section UGC Cost Estimates			
		Meath-Cavan, EirGrid (€M)	Cavan-Tyrone, EirGrid (€M)	Cavan-Tyrone, NIE (€M)	Whole Route (€M)
1	6.26	260	-	-	260
2	6.26	-	26	28	54
2a	6.38	-	144	137	281
2aa	6.38	-	-	40	40
2ab	6.38	-	58	-	58
2b	6.38	20	76	-	96
2bb	6.38	69	-	-	69
Totals		348	304	204	857

Source: T8-18, T8-19

T8-20

98. The following table states our assumption about the appropriate discount rate for the lifetime cost calculations (see also text, Paragraph 81).
99. The same table also contains our assumptions about average maintenance costs over the life of the equipment for the different technology options. In each case the assumption is expressed as percentage of capital cost per year:

Table 8-21, p101 – Cash Flow Discount Rate and Maintenance

Cash Flow Discount Rate (%) =	8.1
-------------------------------	-----

O&M - OHL (% of capital cost of OHL, pa) =	0.2
O&M - UGC (% of capital cost of UGC, pa) =	0.025
O&M - HVDC (% of capital cost of converters, pa) =	0.4

Source: Parsons Brinckerhoff

T8-21

Table 8-22, p115 – UGC Discounted Cash Flow – Lifetime Costs

The table presented here is an augmented version of that presented in the 2009 Report. Extra columns are provided to allow present values to be seen separately for interest during construction, end of life replacement and operating costs. Discount rate is 8.1%:

AC Underground Cable - 400kV XLPE - 1200 sqmm Aluminium - 2 Core/ph - 500MW Load, 400Mvar Comp every 30km:											
Year	Electrical Losses		Costs (€M)								
	Energy Losses (GWh.pa)	Power losses (MW)	Circuit Construction Capital	IDC	Total Construction + IDC	End-of-life Replacement	Annual Energy Losses	Annualised Power Losses	Annual O&M	Total Operating Costs	Total Cashflow
1			428.4	17.4	445.8						446
2			428.4	52.1	480.5						480
3	103.2	16.5					6.3	1.7	0.2	8.2	8
4	103.2	16.5					6.3	1.7	0.2	8.2	8
5	103.2	16.5					6.3	1.7	0.2	8.2	8
39	103.2	16.5					6.3	1.7	0.2	8.2	8
40	103.2	16.5				972.5	6.3	1.7	0.2	8.2	981
Totals	3,922		857	69	926	973	238	64	8	310	2,209
40 year PV (€M)			825	66	890	47	68	18	2	88	1,025

Sources: Various - see N-S Link 2009 text.

T8-22

The acronyms used in the column headings of this table are explained below Table 8-4, on page 20 above.

Section 8.4 HVDC Costs: Table 8-23 – Table 8-23a

100. In the HVDC costs tables we have omitted the classic LCC converter technology, concentrating instead upon the VSC approach. This is because VSC technical characteristics are more applicable to the Irish N-S Link than LCC.
101. Cost estimates are based upon a +/- 320 kV bipole arrangement (as is, for example, the France Spain interconnector currently being delivered) since we believe that this provides the optimum balance of HVDC transmission capacity, control facility and service track record. For a single HVDC circuit this would require two aluminium cable cores per pole (in the same way that a single circuit AC underground option would require two aluminium cable cores per phase) – and we have assumed 1600 mm² conductors for the HVDC option.
102. Although the stated requirement for the N-S Link interconnector is 1500 MVA, no HVDC VSC converter of this size has ever been built. Without a track record for a 1500 MW converter it is difficult for NIE and EirGrid to be confident of the performance of such a device, if ordered, or indeed of its delivery date. However, 720 MW units have been ordered for the Swedish South Western Link, the first of which are due to be in service in 2014. We have thus based our cost estimate on two identical, parallel-running 3-terminal links, each with a capacity of 720 MW.
103. With this arrangement, two, electrically independent, 720 MW converters would be installed at each of the substations at Turleenan, Kingscourt and Woodland.
104. Regarding transmission capacity, the difference in transfer capacity between 1440 MW DC and 1500 MVA AC is negligible, and either would be acceptable to both of the Irish transmission system operators.
105. We note that, whilst the nominal transfer capacity of the HVDC option would be 1440 MW, converter and underground cable losses would require additional power input to the link. Depending upon the power transfer and the configuration of the multi-terminal link, losses could vary – see Table 8-23a, Page 35.
106. When weighing the pros and cons of AC and DC, it is worth noting that, under emergency conditions, AC networks are able to “give a little”, and can offer extra capacity in the short term to overcome the emergency. However, HVDC networks do not have this characteristic. It is thus necessary to be certain that an HVDC link is specified to meet all anticipated emergency conditions.)
107. Turning to the transmission itself, we have estimated the construction costs for both HVDC overhead line and HVDC underground cable, as these were both presented in the original Table 8-23. However, we have then concentrated on the underground option for lifetime cost estimates since, although there would be a lower visual impact from HVDC OHL than from the AC equivalent, some impact would still be likely.
108. Just as for the AC options’ costs presented in the previous sections, the HVDC cost estimates here are based on the DECC Costing Study, and the information is then adjusted to the present day and to meet the particular requirements of this interconnector.
109. Apart from the HVDC overhead lines mentioned in Paragraph 107, the equipment costed for the HVDC technology option comprises (i) two +/-320 kV cable pairs from Turleenan to Kingscourt, and (ii) a further two +/-320 kV cable pairs from Kingscourt to Woodland. At each substation we have costed (iii) two 720 MVA HVDC VSC converter stations, each connected as a symmetrical monopole. Finally, at Kingscourt, we have costed (iv) two HVDC busbars and associated offline HVDC selectors, which would allow the remaining two stations on either connector to operate in the event of the failure of the third station.

110. The costed HVDC equipment is indicated in red in the following diagram.

Figure 3 - Costed and Non-Costed Equipment – the HVDC Underground Option

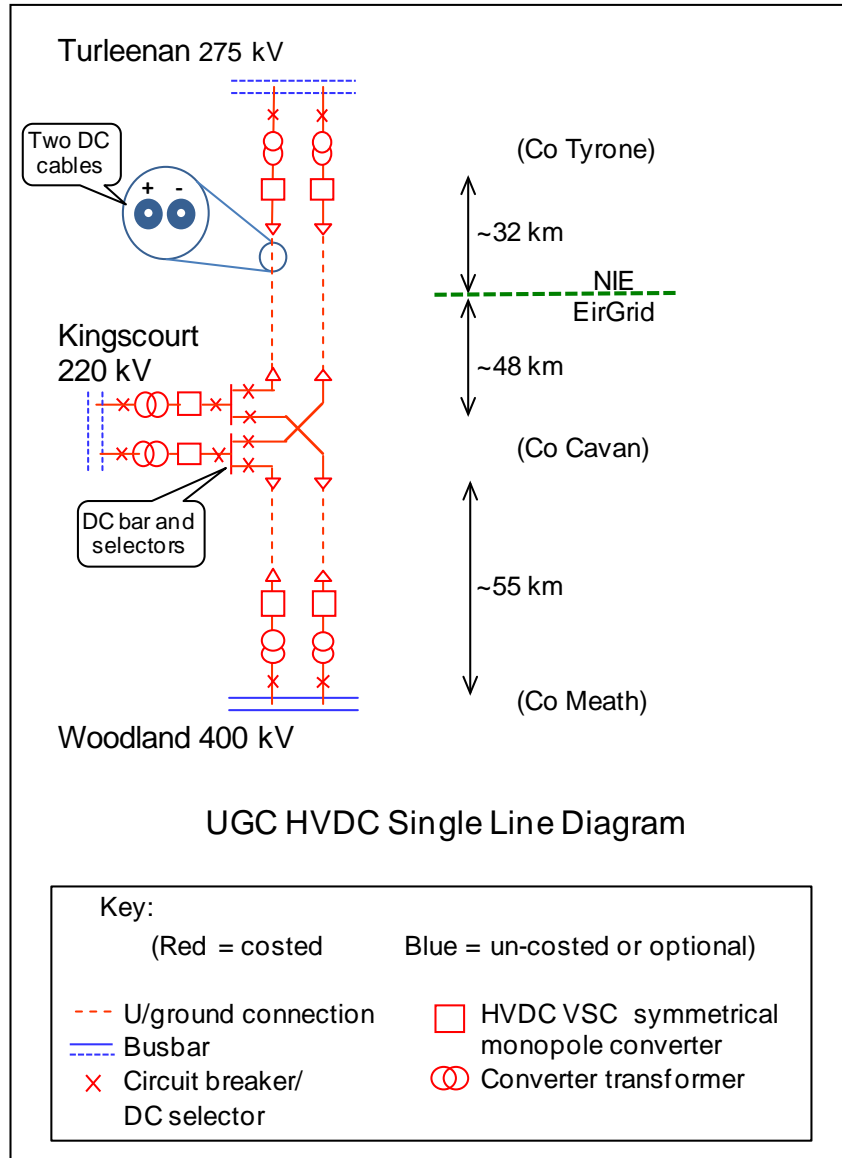

Source: Parsons Brinckerhoff - see Section 1.4 for further details.

3.4.3 Assumptions

111. Other assumptions we have made include:

- i. An assumption that, since there would be two electrically independent HVDC links, a symmetrical monopole arrangement without neutral return would be acceptable to the system operator. The arrangement depicted in Figure 3 uses a symmetrical monopole configuration so, as indicated in the diagram, only 2 HVDC cables are required for each three-terminal link – a total of 4 cables running in parallel. No “neutral” or earth return cable has been costed.

- ii. Each converter would require up to 5 days maintenance outage each year, with a consequent loss of transmission capacity of that section of the N-S Link for that period.
- iii. We have assumed a 500 MW average load for calculating losses (as assumed for the AC options). We have interpreted this as two locations contributing around 375 MW each, and the third end extracting 750 MW. Such an arrangement would result in around 0.6% losses for the three converters together, and this is the level of converter losses we have assumed for these calculations. (To put this assumption into context, two VSC converters are normally assumed to have a total of around 1.8% losses between them at full load.)
- iv. For simplicity, cable losses for the entire route length have been calculated for a 500 MW load.

3.4.4 Strategic Spares Holding

112. One aspect of the HVDC option which we have not costed here, but which could have significant cost and would need careful consideration, is that of strategic spares. The 6 converters would be unique on the all-island transmission network so, unlike much of the equipment required for the AC alternatives, there would be no pre-existing stock of spares. Since the availability of replacement parts in the event of equipment failure has a large bearing on the availability – and thus the commercial viability – of the whole installation, a careful study of appropriate stock levels of key items would need to be made. We do not include a recommendation for stock-value here since such a cost benefit analysis is beyond the scope of this study.

3.4.5 The Tables

113. The following tables incorporate our cost estimate updates for the HVDC tables in the 2009 Report. Regarding the first table, Table 8-23, the 2009 version included costs for an LCC HVDC option as well as for VSC. However, the LCC option has been excluded from this update, as mentioned in Paragraphs 44 and 100, so the converter cost estimates in this table now all relate to VSC converters.

Table 8-23, p116 – Comparative costs of HVDC solutions

(€M)	Build costs	Running costs
Overhead Line:		
3 Converters	445	
Whole route overhead line	107	
Totals	552	
Underground Cable:		
3 Converters	445	See Table T8-23a
Whole route underground cable	508	
Totals	953	

Source: DECC Costing Study

T8-23 & para 473

Table 8-23a – HVDC with UGC Discounted Cash Flow – Lifetime Costs

This is a new table, not presented in the original N-S Link 2009 Report. It provides further detail on the lifetime cost estimates of the HVDC option using underground cable. Energy and power losses depend upon a complex set of link and load configurations, but this example relates to an average of 34% (500 MW) transfer. At peak loading, and depending upon configuration, we estimate that losses might rise to a little over 32 MW (~ 97% efficiency). Discount rate is 8.1%:

VSC HVDC - 1200 sqmm Aluminium XLPE Underground Cable - 2 Core/pole - 500MW Load											
Year	Electrical Losses		Costs (€M)								
	Energy Losses (GWh.pa)	Power losses (MW)	Circuit Construction Capital	IDC	Total Construction + IDC	Mid-life refurbishment + End-of-life Replacement	Annual Energy Losses	Annualised Power Losses	Annual O&M	Total Operating Costs	Total Cashflow
1			476.5	19.3	496						496
2			476.5	57.9	534						534
3	87.1	10.1					5.3	1.0	3.8	10.1	10
4	87.1	10.1					5.3	1.0	3.8	10.1	10
5	87.1	10.1					5.3	1.0	3.8	10.1	10
20	87.1	10.1					5.3	1.0	3.8	10.1	10
21	87.1	10.1				7.3	5.3	1.0	3.8	10.1	17
22	87.1	10.1					5.3	1.0	3.8	10.1	10
39	87.1	10.1					5.3	1.0	3.8	10.1	10
40	87.1	10.1				1,082	5.3	1.0	3.8	10.1	1,092
Totals	3,311		953	77	1,030	1,089	201	39	145	385	2,504
40 year PV (€M)			917	73	990	53	57	11	41	110	1,153

Sources: Various - see N-S Link 2009 text.

T8-23a

The acronyms used in the column headings of this table are explained below Table 8-4, on page 20 above.

3.5 Switchgear and Transformer Costs

114. As an addition to the costs provided in the 2009 Report, we offer here some estimates for the switchgear and transformer costs associated with each transmission option. This is because the technology options do not all require the same amount of switchgear or the same number of transformers, and so where these requirements differ between options we can make a more like-for-like comparison of the technology options' costs by including the switchgear and transformer costs that are dependent upon technology option.
115. The switchgear we have costed is indicated in the single line diagrams of Figure 1, Figure 2, and Figure 3. These items are dependent upon the technology option being considered, and it may be inferred from these diagrams that our cost estimates for Turleenan and Kingscourt don't include all the costs for developing new substations at these two sites. [Omitting, in this way, the development costs that are common to all technology options, is in line with the objective of this study, which is to establish cost differences between the technology options. Since we have excluded from the assessment the cost of project elements common to all options, our estimates should not be construed as comprising the full costs of the N-S Link.]
116. Regarding the AC options, both overhead and underground, since the proposed AC overhead line is specified at 400kV, transformers and associated switchgear are assumed at both Kingscourt (220 kV) and Turleenan (275 kV) – see also Paragraph 87 and Assumption (iii) at Paragraph 89. In addition, at Kingscourt, there would be the need to manage the connections going south and north. Since no 400 kV substation exists there at present, we have included costs for a single busbar substation that would allow any two of the three connections to continue to operate in the event of a failure of the third connection. See Paragraph 94 for a brief explanation of the differences between the OHL and UGC AC connections.
117. Regarding the HVDC option, all three connections would require HVDC converter stations, of which transformers already form an integral part. Thus, whilst AC connections would still be required at all three substations, the AC switchgear would be simpler, and thus less costly than for AC. However, in order to retain operational flexibility, the costs of a DC selector arrangement at, or near, Kingscourt are included – see paragraphs 57 and 109.
118. The following table indicates the switchgear costs that could be anticipated at each connection point for the AC and the HVDC options. We have designated this new table as Table 8-23b:

Table 8-23b – Switchgear Cost Estimates

	Switchgear - AC OHL (€M)	Switchgear - AC UGC (€M)	Switchgear - HVDC (€M)
Turleenan	18.0	20.0	3.7
Kingscourt	21.1	23.2	7.6
Woodland	1.7	2.7	3.3
Total	40.7	45.9	14.7

Sources: Parsons Brinckerhoff

T8-23b

119. These switchgear costs are added into the overall technology comparisons in Table 9-1 “Summary of Cost Estimates for the N-S Link. (That table also appears in the Executive Summary.)

4 THE CHAPTER 9 COSTS CONCLUSIONS

4.1 Paragraphs 542 to 548 in Section 9.3 of the 2009 Report

120. Cost estimate updates for the AC and VSC HVDC options for the proposed N-S Link interconnector are summarised in the following table. The €M values have been rounded to the nearest €5M, however the ratios (the last two lines) have been calculated from unrounded results:

Table 9-1, p136 – Summary of Cost Estimates for the Whole N-S Link

	Total: Turleenan - Kingscourt - Woodland €M		
	AC OHL (base case)	AC UGC	HVDC-VSC UGC
Construction + IDC	125	890	990
Transformers and switchgear	40	45	15
Construction Total	165	935	1005
Lifetime running	55	90	110
40 year replacement	5	45	55
Whole of life Total	225	1070	1170
Lifetime difference above OHL (€M)	0	845	945
Construction difference ratio (times)	1	5.7	6.1
Lifetime difference ratio (times)	1	4.8	5.2

Source: Tables in this Addendum

121. The above costs are presented separately for each Company – NIE and EirGrid – in Appendix B.
122. The first column of this summary Table 9-1 relates to the 1500 MVA 400 kV AC single circuit overhead line option, including associated switchgear at the three substations. It indicates that the estimate to construct the equipment, including interest during construction, is €165M. The present value of the lifetime running costs (which are mainly caused by electrical losses) would be expected to amount to around a further €55M, and the present value to replace the equipment as new at the end of its nominal 40 year asset life, would be in the order of €5M, including a 5% dismantling charge for the equipment being replaced. The whole-of-life cost of the overhead line option is thus estimated at €225M.
123. The middle column indicates the equivalent set of costs for the 400 kV AC underground cable option, again including associated switchgear at the three substations. Construction costs are estimated at €935M, or 5.7 times that of overhead line. Lifetime running costs (losses) are estimated at €90M, and end-of-life replacement at €45M. The whole of life total cost is thus estimated at €1070M, or 4.8 times greater than that of the electrically equivalent overhead line.
124. The final column of Table 9-1 indicates the equivalent costs for six +/- 320 kV 720 MW VSC HVDC terminals connected together with underground cable and appropriate AC and HVDC switchgear (the latter including only currently available technology, offline

HVDC selectors). Construction costs are estimated at around €1005M, or 6.1 times that of the AC overhead line alternative. Lifetime running costs (mainly losses) are estimated at €110M, and end-of-life replacement at €55M. The whole of life total cost is thus estimated at €1170M, some 5.2 times the cost of the electrically equivalent overhead line.

4.2 Paragraphs 551 to 553 in Section 9.4 of the 2009 Report

125. The most cost effective solution for the proposed N-S Link would be to use AC overhead line, estimated to cost around €165M to construct and around a further 35% of this to run, over its lifetime.
126. An AC underground cable is estimated to cost over 5.7 times as much as AC overhead line to construct, and would also cost significantly more than overhead line to run, over its lifetime.
127. Similarly, HVDC UGC links would be expected to cost 6 times as much as AC overhead line to construct, and would then cost twice as much as overhead line to run, over its lifetime.

5 BIBLIOGRAPHY

1. **Parsons Brinckerhoff and Associates.** *The "2009 Report": Cavan-Tyrone and Meath-Cavan 400 kV Transmission Circuits - Comparison of High Voltage transmission Options: Alternating Current Overhead and Underground, and Direct Current Underground. Final Report.* Prepared February 2009.
2. **Government of the Republic of Ireland.** *The "RoI IEC 2011 Review": Meath-Tyrone Report – Review by the International Expert Commission.* s.l. : Commissioned by the Minister for Energy, Pat Rabbitte, 5 July 2011, Dated August – November 2011, Published January 2012.
3. **Parsons Brinckerhoff and Associates.** *The "DECC Costing Study": Electricity Transmission Costing Study - An Independent Report Endorsed by the Institution of Engineering and Technology. Issue 1.1 with Errata.* s.l. : IET at <http://www.theiet.org/factfiles/transmission.cfm>, Issue 1.1 published April 2012.
4. **Siemens, Erlangen, Germany.** France-Spain Interconnector press release. [Online] 12 January 2011. http://www.energy.siemens.com/hq/pool/hq/power-transmission/HVDC/HVDC-PLUS/pm-pdf/INELFE_en.pdf.
5. **ABB, Zurich, Switzerland.** Norway-Denmark Interconnector Press release. [Online] 10 February 2011. <http://www.abb.co.uk/industries/ap/db0003db004333/448a5eca0d6e15d3c12578310031e3a7.aspx>.
6. **ABB.** East West Interconnector (Ireland-UK). [Online] [Cited: 19 March 2013.] <http://www.abb.com/industries/ap/db0003db004333/a60fb5e59414e817c125774a002f365b.aspx>.
7. **CER - Commission for Energy Regulation.** *"AIP/SEM/12/078": Single Electricity Market - Fixed Cost of a Best New Entrant Peaking Plant, Capacity Requirement and Annual Capacity Payment Sum for the Calendar Year 2013.* s.l. : http://www.allislandproject.org/en/cp_current-consultations.aspx?article=75c548a7-34ee-497c-afd2-62f8aa0062df, Published 31 August 2012.
8. **SEMO - Single Electricity Market Operator.** *System Marginal Price for all gates (EA, EP1, EP2 and from August 2012 EA2, WD1) from 11.12.07 - 18.02.2013.* s.l. : <http://www.sem-o.com/Publications/General/SMP2007-2013.xls>, Published February 2013.

6 GLOSSARY AND ACRONYMS

2009 Report	Parsons Brinckerhoff feasibility and costs estimating study for the N-S Link - see Bibliography
AC	alternating current
Addendum	This 2013 document, which presents updated cost estimates from the original 2009 Report.
BEAMA	British Electrotechnical and Allied Manufacturers' Association
CBS	cement-bound-sand - the material traditionally used to surround direct-buried high-voltage cables to stabilise the cable temperature
CER	Commission for Energy Regulation
CSC, LCC	current-sourced-, or line-commutated- converter - the "classic" design of HVDC converter
DCF	discounted cash flow
DECC Costing Study	UK Department of Energy and Climate Change (DECC) Electricity Transmission Costing Study by Parsons Brinckerhoff - see Bibliography
DECC	Department of Energy and Climate Change
EirGrid	EirGrid plc
EIS	Environmental Impact Statement
E-W Interconnector	East-West Interconnector, the 500 MW VSC HVDC link From Woodlands Substation, Meath, to Deeside Substation, UK
HVDC	high voltage direct current
IDC	interest during construction
LCC	See CSC
LRMC	long-run marginal cost
NI	Northern Ireland
NIE	Northern Ireland Electricity Ltd
N-S Link	North-South Link - the proposed pair of single transmission circuits linking Tyrone to Cavan and Cavan to Meath
O&M	operation and maintenance
OHL	overhead line
RoI IEC 2011 Review	International Expert Commission Review of the N-S Link - see bibliography
RoI IEC	International Expert Commission
RoI	Republic of Ireland
SEMO	Single Electricity Market Operator for Ireland
SRMC	short-run marginal cost
UGC	underground cables
VSC	voltage sourced converter - the more recent design of HVDC converter, sometimes referred to as "light".
WACC	weighted average cost of capital

Appendix A - International Expert Commission (RoI IEC) Review - Responses

A.1 Introduction

The previously referenced RoI IEC 2011 Review, that was commissioned by the Government of Ireland, made a number of observations regarding the February 2009 Report. The RoI IEC's observations with particular relevance to the scope of this Addendum, along with brief responses to the observations, are presented here.

A.2 HVDC Technology Options, including VSC

The RoI IEC 2011 Review noted (page 10) regarding the consideration of the HVDC option, that "... most attention is paid to line commutated HVDC and almost none to the modern Voltage Source Converter (VSC) version. Today the situation is entirely different compared to when the report was written regarding technical data such as commercial availability of higher voltages and significantly lower losses".

Response – The impact of recent advances in VSC HVDC technology on transmission costs are taken into account by the cost estimates in this Addendum.

A.3 Availability of HVDC Circuit Breakers

The RoI IEC 2011 Review (Page 26) noted regarding the consideration of the HVDC option that "DC breakers are under development and are expected to be commercially available on the market in 2013. This allows increased flexibility for construction of DC Grids."

And again, on Page 62, the Review noted "With a VSC HVDC it will in the near future (availability of DC breakers) be possible to expand the system to a multi-terminal system (compare with the South-West Interconnector between Sweden and Norway). This will reduce the number of converters and make the expansions relatively cheaper."

Response – The availability of DC breakers, and their possible operational impact upon an HVDC option for the N-S Link, is discussed in Future Availability of HVDC Circuit Breakers, Page 10 of this Addendum.

A.4 Availability of HVDC Circuit Breakers

When members of the RoI IEC appeared before the parliamentary committee in February 2012 there was some discussion about the possibility of rationalising on number of HVDC converters once DC breakers became available. In particular it was said that there might be some savings to be made by sharing the converter installed at Woodland Substation for the East West HVDC Interconnector with the proposed N-S Link.

Response – This concept is discussed in "2.4.4 Relevance of East-West Interconnector Infrastructure", Page 12 of this document.

Appendix B – Summary Cost by Company

B.1 Introduction

This appendix presents an NIE / EirGrid breakdown of the costs summary given in Table 9-1 on Page 38. Note that the cost ratios in these estimates are not identical for the two companies simply because the distribution of equipment (and therefore cost) between the two jurisdictions is not balanced in the same way for each technology alternative.

Firstly, Table 9-1 is provided again below, for easy reference, then overleaf these figures are split between NIE and EirGrid according to the costs that are expected to be incurred each side of the border. Please note that some rounding errors occur in the breakdowns.

B.2 Total Tyrone–Cavan–Meath Route Costs Summary (Table 9-1)

(Figures rounded to nearest €5M)

Total: Turleenan - Kingscourt - Woodland €M			
	AC OHL (base case)	AC UGC	HVDC-VSC UGC
Construction + IDC	125	890	990
Transformers and switchgear	40	45	15
Construction Total	165	935	1005
Lifetime running	55	90	110
40 year replacement	5	45	55
Whole of life Total	225	1070	1170
Lifetime difference above OHL (€M)	0	845	945
Construction difference ratio (times)	1	5.7	6.1
Lifetime difference ratio (times)	1	4.8	5.2

Source: Tables in this Addendum

B.3 NIE Costs Summary

(Figures rounded to nearest €5M)

NIE proportion - €M			
	AC OHL (base case)	AC UGC	HVDC-VSC UGC
Construction + IDC	30	210	280
Transformers and switchgear	20	20	5
Construction Total	45	230	285
Lifetime running	15	20	35
40 year replacement	0	10	15
Whole of life Total	60	265	335
Lifetime difference above OHL (€M)	0	200	275
Construction difference ratio (times)	1	4.9	6.0
Lifetime difference ratio (times)	1	4.3	5.5

Source: Tables in this Addendum

B.4 EirGrid Costs Summary

(Figures rounded to nearest €5M)

EirGrid proportion - €M			
	AC OHL (base case)	AC UGC	HVDC-VSC UGC
Construction + IDC	95	680	710
Transformers and switchgear	25	25	10
Construction Total	115	705	720
Lifetime running	40	65	75
40 year replacement	5	35	40
Whole of life Total	160	810	835
Lifetime difference above OHL (€M)	0	645	670
Construction difference ratio (times)	1	6.1	6.2
Lifetime difference ratio (times)	1	5.0	5.1

Source: Tables in this Addendum



July 2013

CAVAN-TYRONE & MEATH-CAVAN 400 KV TRANSMISSION CIRCUITS

TECHNOLOGY AND COSTS UPDATE

Supplementary Note

**PARSONS
BRINCKERHOFF**

Supplementary Note to the Technology and Cost Update Addendum Implications of EirGrid’s Decision to Defer Kingscourt Substation

1 INTRODUCTION

1. On 16th April 2013 EirGrid published its North–South 400kV Interconnection Development: Final Re-evaluation Report. In this report EirGrid announced its decision to defer the intermediate substation near Kingscourt. A consequence of the deferment of the substation, regardless of which technology option is chosen, is that it would reduce the initial investment required to develop the N-S Link, so EirGrid has requested Parsons Brinckerhoff to provide an indication of the impact of the deferment on the initial investment.
2. The deferment of Kingscourt would not cause the same reduction in investment for each transmission technology option. We provide below, therefore, references to our April 2013 Comparison of High Voltage Transmission Options [1] (referred to below as the Addendum) for each technology option, to determine whether the Kingscourt deferment would alter the conclusions of the comparative costing study. This supplementary note should be read in conjunction with the April 2013 Addendum.

2 REVISED COSTS ESTIMATES

3. The following figures provide a simple overview of the differences in estimated capital costs of each technology, and do not take into account interest during construction, operating costs, or the time value of money (discounted cash flow).
4. Please note that figures in this section are rounded to the nearest €1 million.

Table 2-1 HVAC OHL Costs (base case)

Item	€M	Notes
Total OHL Construction	118	Refer Column 4, Table 8-4, page 20
Switchgear + transformers	41	Refer Table 8-23b, page 37
Original Capital Cost including Kingscourt	159	
Less Switchgear + transformers at Kingscourt	21	Refer Table 8-23b, page 37
Revised Capital Cost excluding Kingscourt	138	

¹ Parsons Brinckerhoff’s Cavan-Tyrone & Meath-Cavan 400 kV Transmission Circuits – Comparison of High Voltage Transmission Options: Alternating Current Overhead and Underground, and Direct Current Underground – Technology and Costs Update since Publication of the 2009 Report, self-referenced as “the Addendum”.

Table 2-2 HVAC UGC Costs

Item	€M	Notes
Total UGC Construction	857	Refer Column 4, Table 8-22, page 31
Switchgear + transformers	46	Refer Table 8-23b, page 37
Original Capital Cost including Kingscourt	903	
Less Switchgear + transformers at Kingscourt	23	Refer Table 8-23b, page 37
Revised Capital Cost excluding Kingscourt	880	

Table 2-3 HVDC UGC Costs

Item	€M	Notes
Total HVDC UGC Construction	953	Refer Column 4, Table 8-23a, page 35
Switchgear + transformers	15	Refer Table 8-23b page 37
Original Capital Cost including Kingscourt	968	
Less AC/DC Converters at Kingscourt	148	Refer Table 8-23 on page 34 - one third of costs of converters
Less Switchgear + transformers at Kingscourt	8	Refer Table 8-23b, page 37
Revised Capital Cost excluding Kingscourt	812	

5. NOTE: It is stated in Section 1.4 of the Addendum that, as the aim of the study is to estimate the differences in cost between the transmission circuit technology alternatives, the costs of those elements of the overall project which are common to all options have been intentionally excluded (also refer Paragraph 115, page 36). The above cost estimates should not therefore be construed as representing 'whole of project' cost estimates.

3 SUMMARY OF COST ESTIMATES

6. The summary cost estimates for the initial capital investment required for each option and each scenario are shown in the tables below. The costs are rounded to the nearest €5 million.

Table 3-1 Original scenario, inclusive of Kingscourt Substation

Technology Option	Capital Cost (€ million)	Cost Difference compared to base case (€ million)
AC Overhead Line (base case)	160	N/A
AC Underground Cable	905	745
HVDC Underground Cable	970	810

Table 3-2 Revised scenario, excluding Kingscourt Substation

Technology Option	Capital Cost (€ million)	Cost Difference compared to base case (€ million)
AC Overhead Line (base case)	140	N/A
AC Underground Cable	880	740
HVDC Underground Cable	810	670

7. From the above tables it can be seen that the deferment of the costs associated with the substation near Kingscourt has had little or no impact on the difference in the initial capital investment between the HVAC OHL option (base case) and the HVAC UGC option. The cost difference remains in the region of €740M.
8. However, the deferment of Kingscourt has a significant impact on the cost difference between the HVAC OHL option and the HVDC UGC option. With Kingscourt included the cost differential was €810M. Excluding Kingscourt reduces this to €670M.

4 CONCLUSIONS

9. Regardless of which technology option is chosen, the deferment of the substation near Kingscourt will reduce the initial investment required to develop the N-S Link.
10. The most cost effective technology option, however, remains an AC overhead line, estimated to cost around €140M.
11. With the deferment of Kingscourt, AC underground cable becomes the most costly option, estimated at around €880M, or €740M more than the AC overhead line. The deferment of Kingscourt has little or no impact on the cost differential with the AC overhead line as similar costs are deferred in the case of both options
12. The deferment of the substation near Kingscourt will however have a significant impact on the initial investment required to develop the HVDC option. This is due to the very high cost of HVDC converters, and the fact that, with the deferment, converters would only be required initially at Turleenan and Woodland, not at Kingscourt. Under this scenario, the HVDC option, at an estimated cost of around €810M, is no longer the most costly option. It is still, however, €670M more costly than the least cost option AC overhead line.
13. The initial investment cost of the HVDC option is reduced, due to the deferment of the substation near Kingscourt, by around €160M (€970M - €810M), whilst the initial investment costs of the two AC options are only reduced by around €20M - €25M. The disparity of the effects on the AC and HVDC options highlights one major disadvantage of the HVDC option for the Ireland N-S Link. This is that, if the N-S Link is developed using HVDC technology, future 'tap-ins' to the circuit for the substation near Kingscourt and/or for some other as yet unknown requirement at some other location along the route, will be many times more expensive than tapping into an AC circuit.